

SAGINAW CONTROL & ENGINEERING

SCE-MOD8424FEP

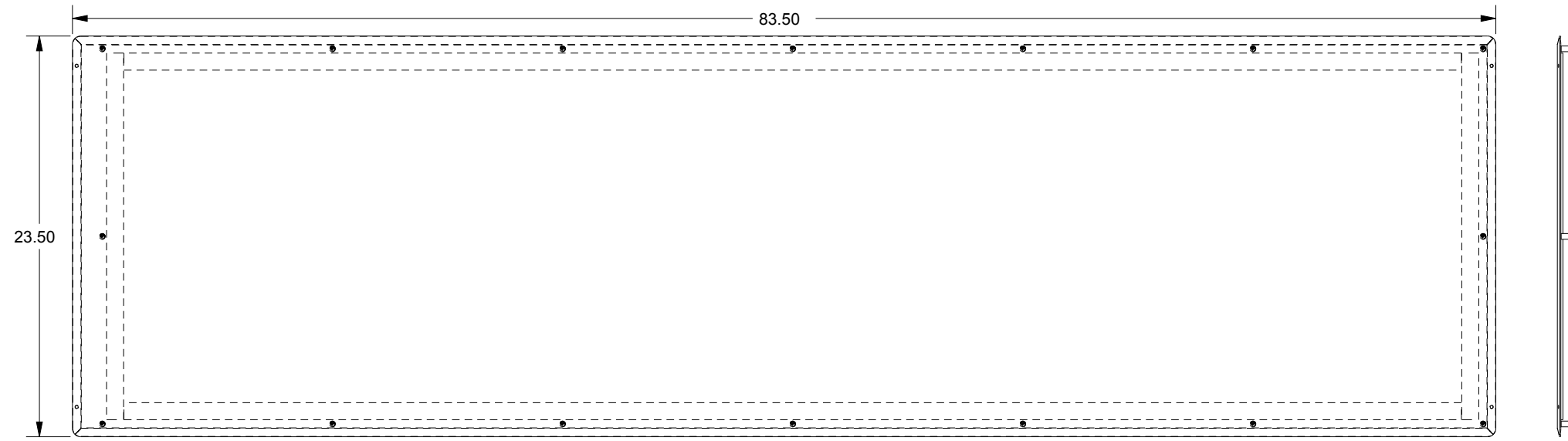

END PANEL FRONT VIEW

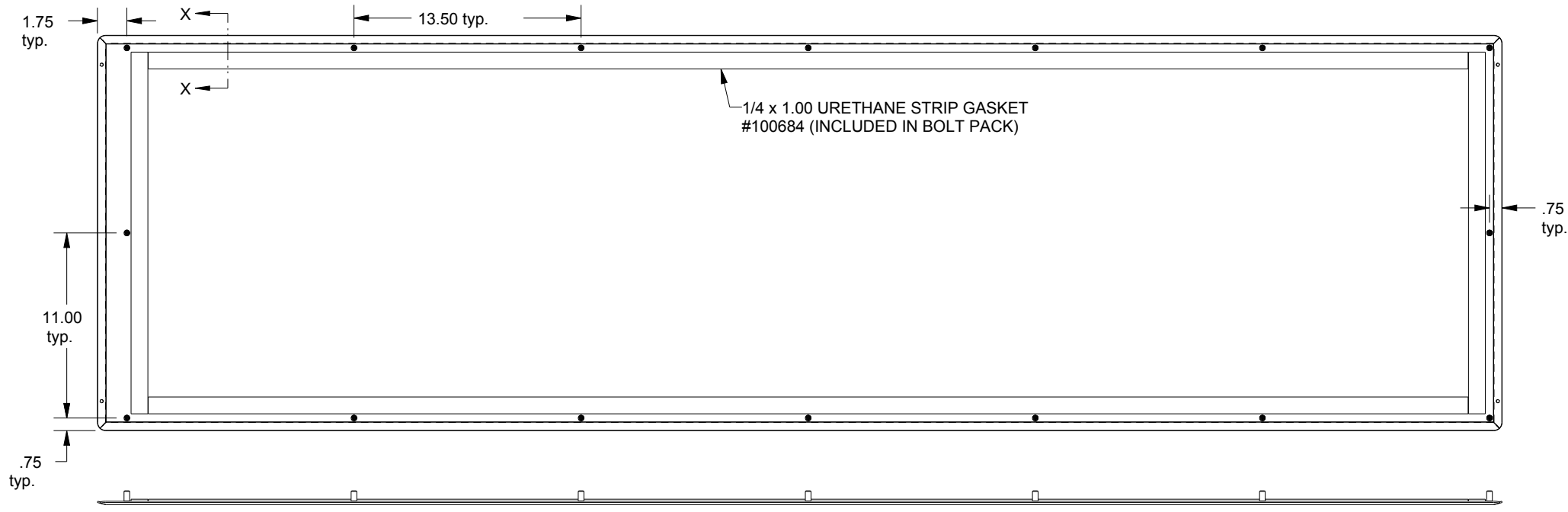